

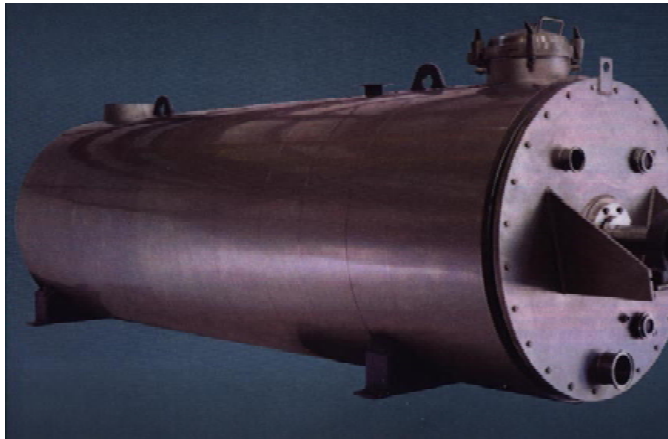

ANCO MODEL 1500 USDA/AG CANADA BATCH COOKER



MODEL 1500 SHOWN IN A STERILIZING APPLICATION

FEATURES- The ANCO® model no. 1500 batch cooker features a removable front head, optional steam heated shaft, saves floor space and provides for more heat transfer surface area than conventional ANCO cookers. Besides drying at atmospheric pressure, it's internal pressure design allows it to be used for multitude of hydrolyzing and sterilizing applications. Applications range from the food, chemical & medical industries to the edible rendering industry. Constructed from the strongest materials including high grade 90,000 psi pressure vessel quality steel as the standard for the inner shell/jacket, and manufactured per ASME code's stringent guidelines provides for exceptional safety, durability, longevity, performance & overall value. Variable pressure rating design and specialized material construction (304-316 stainless steel) can be provided to accommodate customer's needs.

OPTIONS- The model no. 1500 can be equipped with a multitude of options: automatic inlet & outlet material closures, moisture/temperature sensors, weighing cells, variable speed agitator, time/temperature sterilization chart recorders. These elements can be tied into PLC automation controller to save labor, eliminate operator error and provide for optimum product quality.

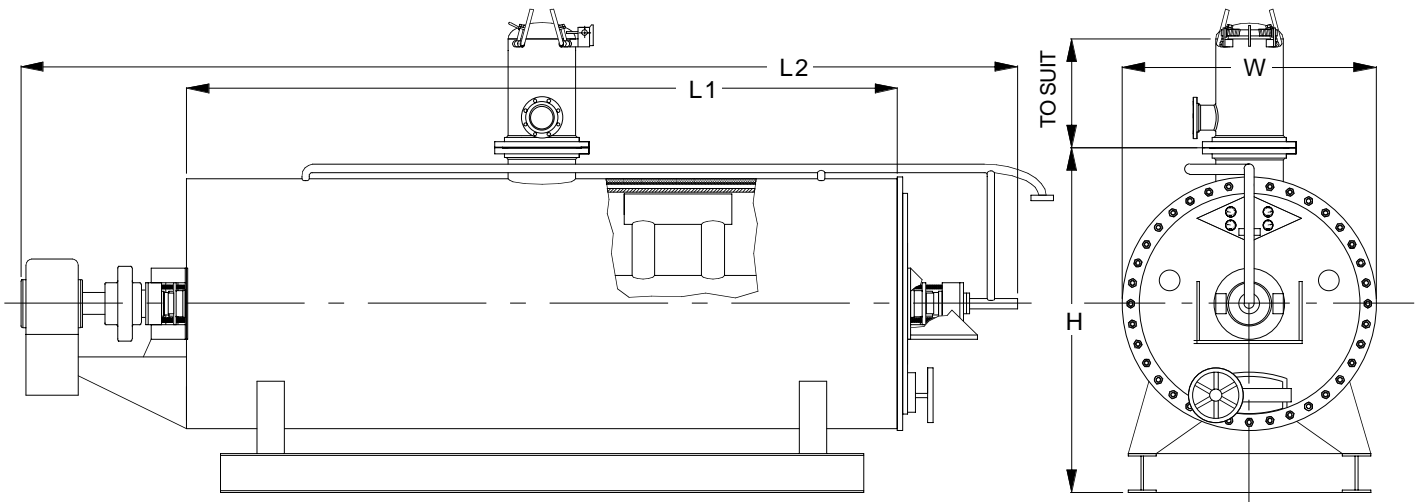

ANCO MODEL NO.	L1		L2		W		H		HEAT TRANSFER AREA		GROSS VOLUME		SHIPPING WT	
	(M)	(FT)	(M)	(FT)	(M)	(FT)	(M)	(FT)	M ²	FT. ²	LITER	CU.FT.	LBS.	KGS
1500-10	5.5	18	7.8	25.5	1.7	5.5	2.5	8.2	53.2	573	10,000	353	40,260	18,300
1500-12.5	5.8	19	8.1	26.5	1.8	5.9	2.6	8.6	61.1	658	12,500	441	50,820	23,100
1500-15	6.1	20	8.4	27.5	2.0	6.7	2.9	9.4	70.4	758	15,000	530	62,040	28,200
1500-20	6.4	21	8.7	28.5	2.3	7.5	3.1	10.2	87.6	943	20,000	706	82,500	37,500

DATA IS APPROXIMATE AND SUBJECT TO CHANGE WITH OUT NOTICE.

Contact **ANCO-EAGLIN** for information about processing capacity and HP requirements for you particular application. The seller makes no warranties, express or implied including but not limited to the implied warranties of the merchantability and fitness for a particular purpose except expressly stated in seller's contract or sales acknowledgement form.

ANCO-EAGLIN, Inc.

120 North Chimney Rock Rd. • Greensboro, North Carolina 27409, USA
 TEL (336) 855-7800 • FAX (336) 855-7831 • E-mail: ancoeaglin@aol.com
 HOME PAGE: www.ancoeaglin.com